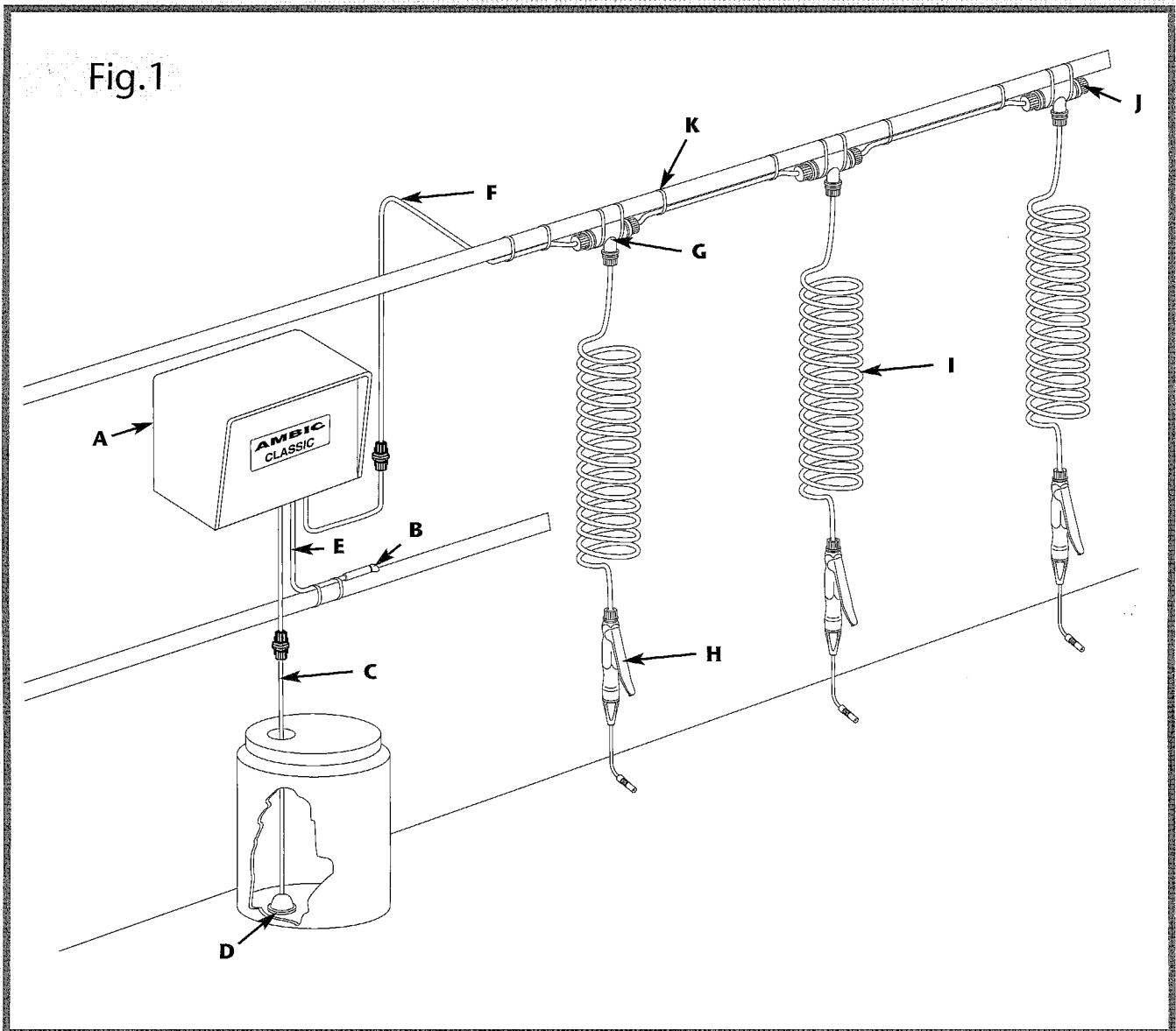


# AMBIC®

## CLASSIC TEAT SPRAY SYSTEM

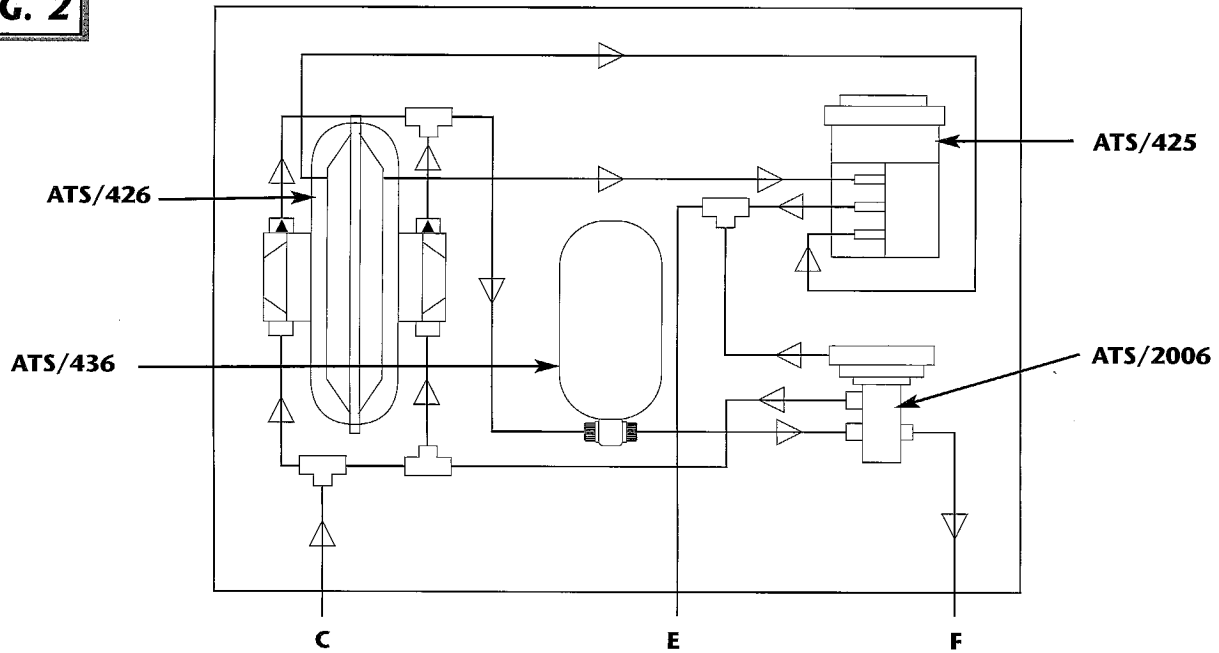


# INSTRUCTIONS

*leading best practice in livestock health management*

# 1. SCHEMATIC LAYOUT

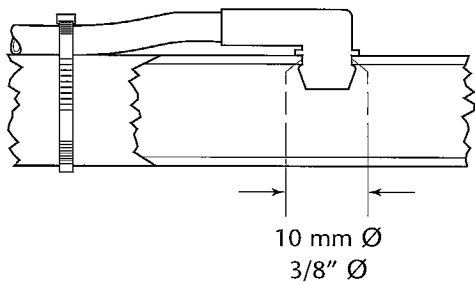
**FIG. 2**



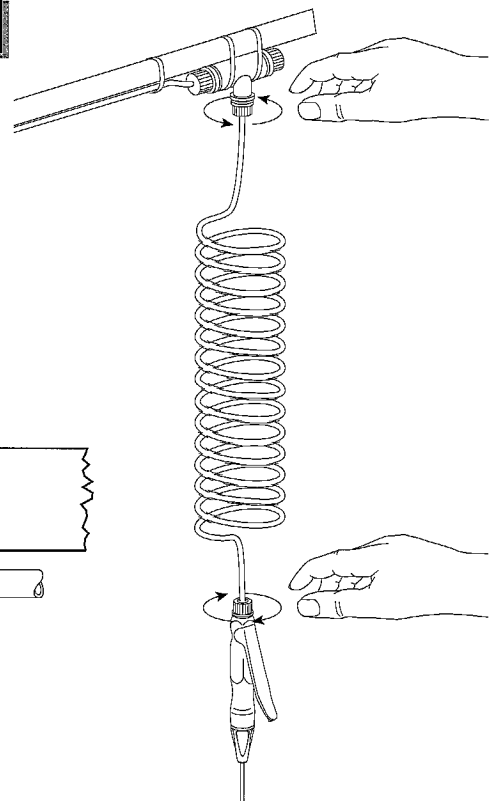
**ATS/401**

# 2. INSTALLATION

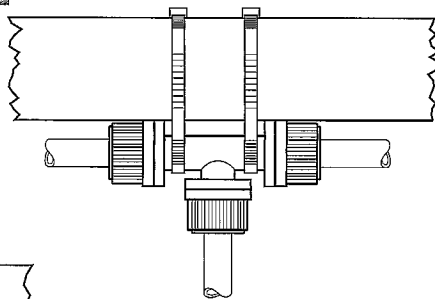
**FIG. 3**



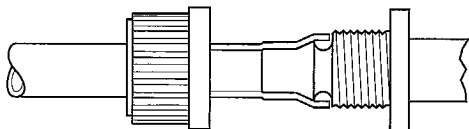
**FIG. 6**



**FIG. 4**

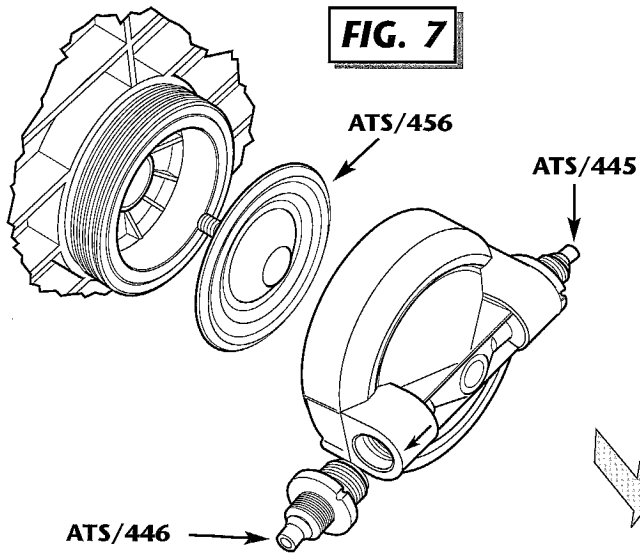


**FIG. 5**

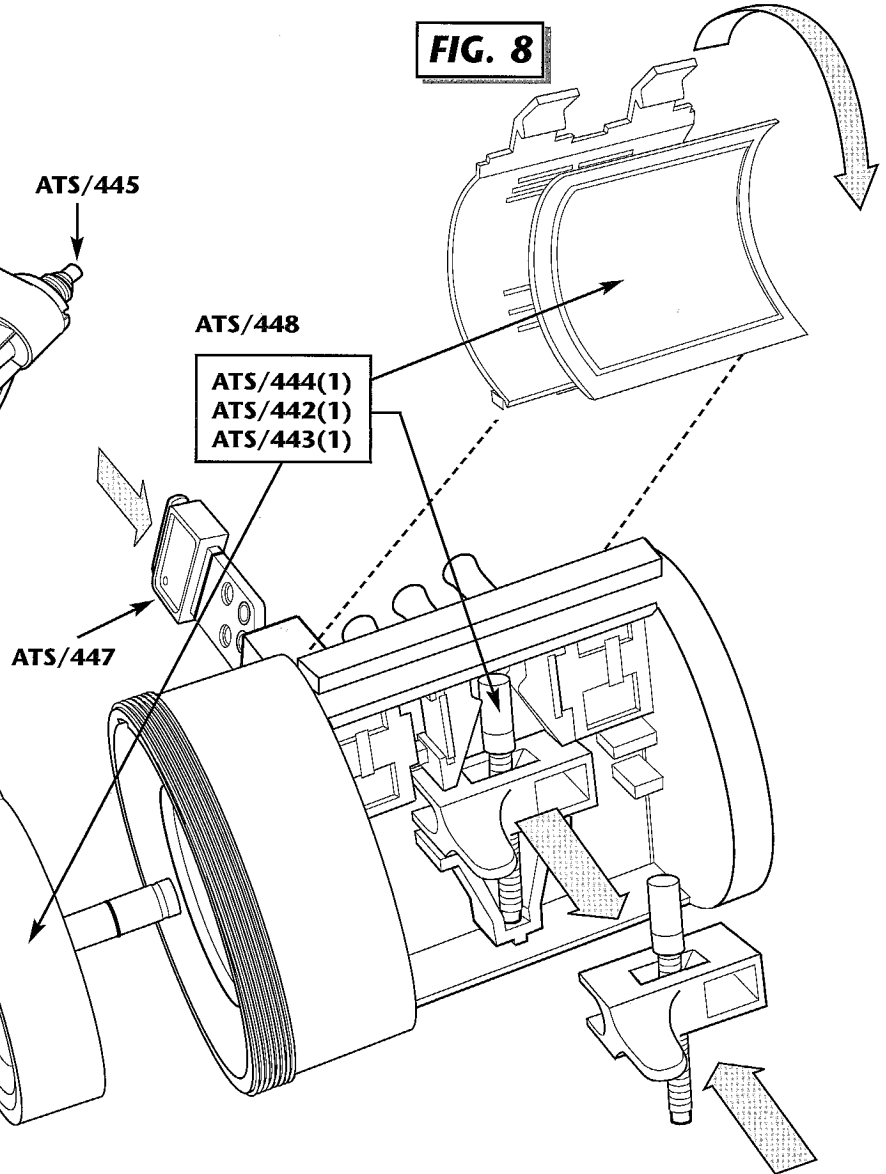


3. MAINTENANCE

**FIG. 7**

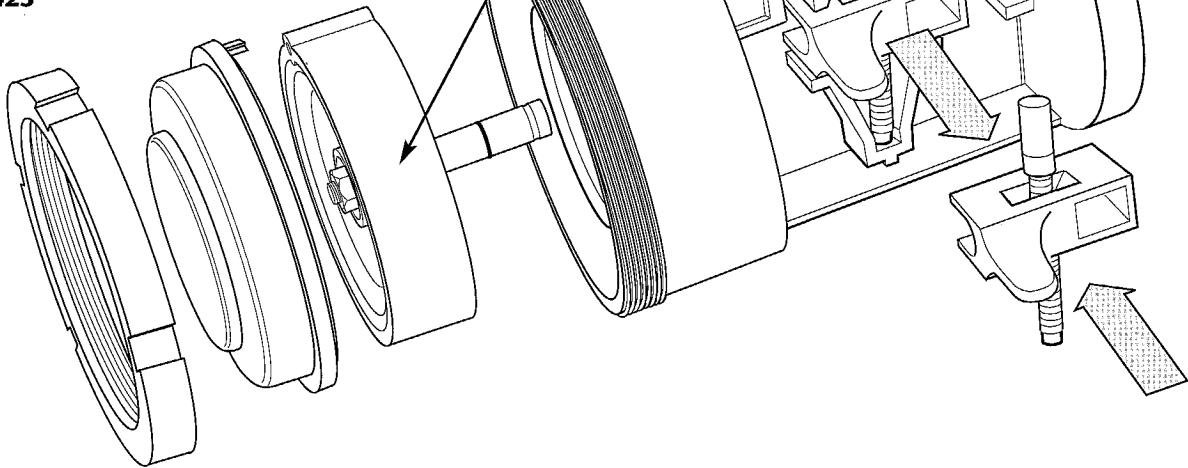


**FIG. 8**



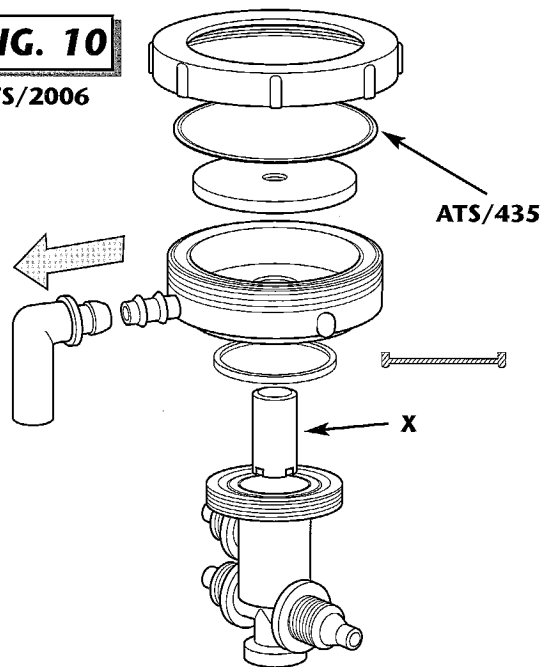
**FIG. 9**

ATS/425



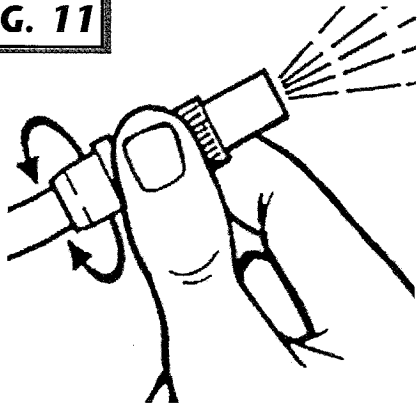
**FIG. 10**

ATS/2006

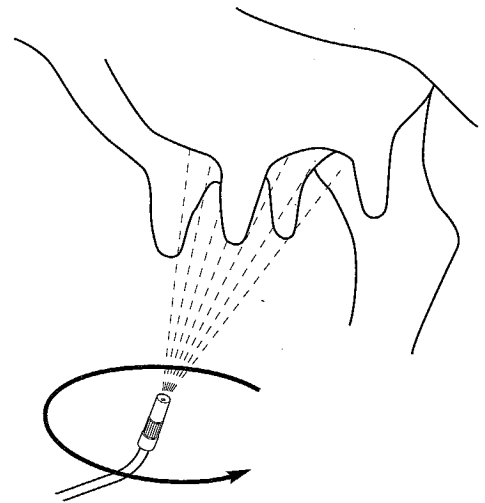


## 4. OPERATION

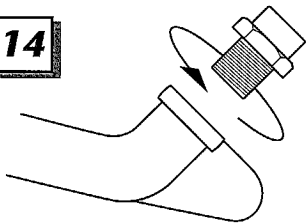
**FIG. 11**



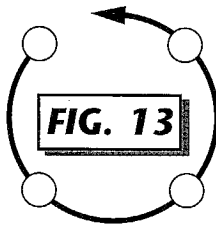
**FIG. 12**



**FIG. 14**



**FIG. 13**



## 5. PARTS LIST (refer to FIG. 1)

| REF | NO      | QTY | DESCRIPTION                 | REF | NO      | QTY | DESCRIPTION      |
|-----|---------|-----|-----------------------------|-----|---------|-----|------------------|
| A   | ATS/401 | 1   | Power Unit                  | H   | ATS/402 | 3   | Spray Guns       |
|     |         | 3   | Screws & Plugs              |     | ATS/502 |     |                  |
| B   | ATS/413 | 1   | Vacuum Pipe Adaptor         | I   | ATS/406 | 3   | Retractable Coil |
| C/D | ATS/412 | 1   | Liquid Intake Pipe + Filter | J   | ATS/429 | 2   | Blanking Plugs   |
| E/F |         | 1   | 18M Transparent Tubing      | K   | ATS/411 | 30  | Cable Ties       |
| G   | ATS/407 | 3   | T. Connectors               |     |         |     |                  |

## 6. SAFETY

The Classic Teat Spray System is designed exclusively for use in milking installations. Any application outside the use described in this operating manual will be taken to be not in accordance with the intended purpose. The manufacturer/supplier will not be held responsible for any losses arising as a result of such use. The user will take full responsibility for use. USE IN ACCORDANCE WITH THE INTENDED PURPOSE ALSO INCLUDES COMPLYING WITH THE OPERATING MANUAL AND THE CONDITIONS FOR INSPECTION AND MAINTENANCE.

**ATTENTION!** Whilst in operation the installation is under an operating pressure of 3 to 4 bar!

Do not spray dip into your eyes! If you do, rinse with copious amounts of water and seek medical attention!

## 7. INSTALLATION

For general parlour layout refer to Fig. 1.

Position Power Unit (A) not more than 2 metres (6ft) above the base of the Chemical Container, preferably in a dust free environment, close to a regulated Vacuum Line.

Screw white bracket to wall securely using 3 x screws and wall plugs supplied. Attach the Power Unit (A) ensuring that the hooks properly engage the rectangular holes in the back plate.

**VACUUM SUPPLY** Drill a 10mm Ø (3/8"Ø) hole in the top of a regulated main vacuum line (FIG. 3). Remove burrs, lubricate Pipe Adapter (B) and twist into hole.

Secure Tube (E) with Cable Ties (K). Do not over-tighten and avoid sharp bends. Cut tube to correct length or leave loosely coiled.

**CHEMICAL INTAKE** Remove the nut and end of line plug from the straight connector on the liquid intake tubing (FIG. 2 C). Place container of chemical in position and insert tube fitted with the filter so that the filter (D) rests on the bottom of the Chemical Container.

Insert tube through nut, warm end of tube to ease assembly and push fully onto inlet straight connector (Fig2 C). Tighten nut firmly with fingers. Do not use pliers or other tools. This method (FIG. 5) should be used when connecting all such fittings on Classic.

**PRESSURE LINE** Remove the end of line plug from the straight connector (FIG. 2 F) on the pressure line and attach one end of the coil of transparent tubing. Retain plug to seal last 'T' connector. Determine position of 'T's (G) and strap loosely to a suitable support (FIG. 4). Cut suitable lengths of Tubing (F) strapping and connecting to 'T's (G) and outlet straight connector. Attach Coils (I) and Guns (H) (FIG. 6). Seal open end of last 'T' with Blanking Plug (J) and Nut.

Finally, once positions are correct, fully tighten Cable Ties. Do not over-tighten on tubing and avoid sharp bends.

## 8. INITIAL START UP

When installation is complete, turn on Vacuum Pump. Power Unit will automatically start, reaching full pressure within 1 minute.

There will be some air in the system. To expel this, hold each gun vertically above the Delivery Line at arms length pointing away from face. Press gun lever until air bubbles are no longer apparent.

## 9. OPERATION

Classic is suitable for use with any recognised Teat Disinfectant Spray except Sodium Hypochlorite and Peroxyacetic Acid. When using concentrates, ensure that the manufacturers

instructions are followed. Agitation may, periodically, be required.

**Important:** Replenish disinfectant supply before it runs out to prevent air entering the system.

**SPRAYING** For effective Mastitis Pathogen control the teats must be completely covered with disinfectant. On adjustable nozzle guns rotate nozzle to achieve correct spray pattern (FIG. 11). Fixed cone nozzles (as on AJS/502) do not require adjustment.

The nozzle should ideally be positioned approximately 15cm (6") below the teats. Optimum and economical coverage is achieved by employing a circular movement (FIG. 12 & 13). Application time will differ between cows; however, on average should be approximately 1 second per cow.

**END OF MILKING** when the main Vacuum Supply is turned off, the Power Unit automatically returns pressurised disinfectant to the Chemical Container. This ensures immediate safety and also flushes any debris from the Intake Filter (D).

## 10. MAINTENANCE

**Working on the Power Unit** Turn off and disconnect vacuum supply and ensure that unit is depressurized BEFORE disconnecting any tubing, by opening/disconnecting one or more guns. Remove the Power Unit to a safe and convenient working surface. Remove the case by undoing the four retaining screws.

**DIRECTIONAL VALVE ATS/425** The Directional Valve (FIG. 2 ATS/425) is mounted at the top right hand side of the Power Unit: this directs vacuum to the Diaphragm Pump. Spare parts are contained in Service Kit ATS/448.

**Complete Replacement**

Unscrew the two retaining screws from the back plate and carefully remove the three vacuum tubes. Warming and noting their order will assist removal and fitting. Refitting is a reversal of removal.

**VALVE FILTER (ATS/444)** Replace every 1000 hours or sooner if heavily contaminated. Manually release Filter Cover Clips by levering with fingers (FIG. 8). Carefully remove Filter taking care not to drop dust into the working parts. Fit new Filter by reversing the process.

**BLEED INSERT ATS/447** Pull out of main body taking care not to dislodge the 4 'O' Rings. Inspect two small holes near the end (FIG. 9) and clean every 1000 hours, or sooner if heavily contaminated, using strand of wire attached to bleed insert.

**DIAPHRAGM ASSEMBLY (ATS/443)** Replace, using ATS/448, every 3000 hours. First remove Valve Filter (see above). Pull Drive Box in direction of Arrow (FIG 9) using pliers on Lug. Remove Spring (ATS/442). Unscrew large black ring nut, gently prise off red cap, using a screwdriver in slot provided. Pull out rubber Diaphragm by grasping outer rim. Replace Spring at same time as Diaphragm replaced.

Fit new Diaphragm Assembly ATS/443 by reversing the operation, taking care not to remove the pre-lubrication on the shaft and ensuring that the semi circular location engages in the recess on the main body. When replacing the Drive Box push hard until a click is heard indicating proper engagement. Prior to fitting the Filter and Cover, push Drive Box from end to end. An audible click should be heard, indicating proper operation.

**DIAPHRAGM PUMP ATS/426** The pump is located on the left of the Power Unit ATS/426 (FIG. 2). It needs no maintenance but, in the rare event of failure, it is easily removed by gently pulling the pump from the two plastic retaining clips on the base. Unscrew 4 Nuts, on the Pump Head, ATS/445 and ATS/446 (FIG. 7), warm tube ends and pull off gently, noting their positions. Replacement of the small pump diaphragms

ATS/456 (FIG. 7) is possible, but it is difficult without the use of specially-adapted tools to hold the body and to unscrew the pump heads.

When replacing the Pump, make sure that the arrows on the Pump Heads point towards the top of the Power Unit. Occasionally, debris may enter the Non Return Valves ATS/445 and ATS/446 (FIG. 7). These can be unscrewed using suitable pliers. Wash out and blow through. These components can be replaced if damaged.

**DUMP/RELIEF VALVE AJS/2006** Valve is located at bottom right of Power Unit AJS/2006 (FIG. 2). To replace Diaphragm ATS/435 (FIG. 10), unscrew top with moulded lugs, this will expose Diaphragm for replacement.

To replace or remove complete Relief Valve, first remove whole unit from wall and undo the one Philips Screw securing the Relief Valve to the base. Unscrew the 3 nuts on the Relief Valve, warm the tube ends and pull off gently noting their positions.

## 11. TROUBLE SHOOTING

| FAULT   | CAUSE  | REMEDY  |
|---|--|---|
| 1. Unit does not spray                                      | <ul style="list-style-type: none"> <li>a. Vacuum Pump not switched on</li> <li>b. Vacuum line not airtight</li> <li>c. Constricted Vacuum Supply Pipe (E)</li> <li>d. Chemical Container is empty</li> <li>e. Intake Filter (D) blocked</li> <li>f. Pressure Line (F) blocked</li> <li>g. Spray Nozzle ATS/415 (or AJS/2415) blocked</li> <li>h. Unsuitable chemical being used</li> <li>i. Pump ATS/426 faulty</li> <li>j. Directional Valve ATS/425 faulty</li> <li>k. Dump Valve AJS/2006 faulty</li> </ul> | <ul style="list-style-type: none"> <li>a. Switch on Vacuum Pump</li> <li>b. Check that Vacuum is reaching Power Unit. Check Vacuum Pipe adaptor is correctly installed</li> <li>c. Check for kinks and overtightened Cable Ties</li> <li>d. Fill Container</li> <li>e. Clean Filter</li> <li>f. Clear blockage, check for kinks, constrictions and tight Cable Ties</li> <li>g. Disassemble, clean Nozzle (see Figs. 11 &amp; 14)</li> <li>h. Change to recognised Teat Disinfectant</li> <li>i. Check Pump and repair or replace</li> <li>j. Check Valve and repair or replace</li> <li>k. Check Valve and clean, repair or replace</li> </ul> |
| 2. Nozzle (Figs.12 & 14) does not shut off cleanly or Leaks | <ul style="list-style-type: none"> <li>a. Air in pressure Line (F)</li> <li>b. Control Valve ATS/405 dirty or damaged</li> </ul>   | <ul style="list-style-type: none"> <li>a. Vent as described under "Initial start up"</li> <li>b. Clean or replace Control Valve</li> </ul>  |
| 3. Chemical running out of Power Unit                       | <ul style="list-style-type: none"> <li>a. Loose Connector Nut</li> <li>b. Defective Pump or Relief valve</li> </ul>  | <ul style="list-style-type: none"> <li>a. Locate leak and tighten Nut</li> <li>b. Check Units and repair or replace</li> </ul>  |
| 4. Unit pressurised when Vacuum switched off                | Relief Valve faulty  | Repair or replace   |
| 5. Chemical leaks into Vacuum line                          | Relief Valve or Pump faulty  | Immediately disconnect Vacuum line & plug it. Repair or replace defective parts.  |

## 12. TECHNICAL DATA

|                      |  |   |              |
|----------------------|--|---|--------------|
| Power Source         | Vacuum 12-15"Hg (40-50 kPa)                | Maximum No. of guns operated simultaneously | 2            |
| Chemical Consumption | 6-14 ml/Sec per gun                        | Maximum No. of Guns per Power Unit          | 20           |
| Air Consumption      | 50 l/min (1.8cfm Atmospheric Air @ 50 kPa) | Maximum length of Pressure Line             | 25 m (80 ft) |
| Spray Pressure       | 40psi (3bar) @ 50 kPa (15"Hg)              |   |              |

### 13. DECLARATION OF CONFORMITY

Manufactured by Ambic Equipment Ltd, Witney, UK

**GB**

#### EC DECLARATION OF CONFORMITY

Name of Product: Automated Teat Sprayer  
Type: ATS/400  
Other identifying data: Serial Number

The Product complies with requirements of the following directives: 89/392/EEC  
91/368/EEC

Harmonized standards which have been used:  
BS EN 292 - 1  
BS EN 292 - 2

Date: 21.12.2004 Signed:

Name: R.J. Hiley  
Position: Product Manager

Name and address of manufacturer:  
Ambic Equipment Ltd. (when applicable)  
1Parkside, Avenue Two  
Station Lane, Witney, Oxford OX28 4YF  
ENGLAND

**D**

#### EC - KONFORMITÄTSERKLÄRUNG

Produktbezeichnung: Automated Teat Sprayer  
Typ: ATS/400  
Andere Identifikationsdaten: Serial Number

Das Produkt unterliegt den Richtlinien folgender Bestimmungen: 89/392/EWG  
91/368/EWG

Übereinstimmende Normen, die genutzt werden:  
BS EN 292 - 1  
BS EN 292 - 2

Datum: 21.12.2004 Unterschrift:

Name: R.J. Hiley  
Position: Product Manager

Name und Anschrift des Herstellers:  
Ambic Equipment Ltd. (falls zutreffend)  
1Parkside, Avenue Two  
Station Lane, Witney, Oxford OX28 4YF  
ENGLAND

**F**

**B**

#### DECLARATION DE CONFORMITE CE

Nom de produit: Automated Teat Sprayer  
Type: ATS/400  
Identification: Serial Number

Ce produit est conforme aux directives suivantes: 89/392/CE  
91/368/CE

Standards d'harmonisation utilisés:  
BS EN 292 - 1  
BS EN 292 - 2

Date: 21.12.2004 Signature:

Nom: R.J. Hiley  
Fonction: Product Manager

Nom et adresse du constructeur:  
Ambic Equipment Ltd. (le cas échéant)  
1Parkside, Avenue Two  
Station Lane, Witney, Oxford OX28 4YF  
ENGLAND

**DK**

#### EC DEKLARATION OM OVERENSSTEMMELSESERKLÆRING

Navn på produkt: Automated Teat Sprayer  
Type: ATS/400  
Andre kendetegn: Serial Number

Produktet opfylder kravene fra følgende direktiver: 89/392/ØF  
91/368/ØF

Harmoniserede standarder som er brugt:  
BS EN 292 - 1  
BS EN 292 - 2

Dato: 21.12.2004 Underskrift:

Navn: R.J. Hiley  
Stilling: Product Manager

Navn og adress på producent:  
Ambic Equipment Ltd. (hvis muligt)  
1Parkside, Avenue Two  
Station Lane, Witney, Oxford OX28 4YF  
ENGLAND

**S**

#### EU-FÖRSÄKRAN OM ÖVERENSSTÄMMELSE ENLIGT EU'S MASKINDIREKTIV

Produktnamn: Automated Teat Sprayer  
Typ: ATS/400  
Identitet: Serial Number

Produkten uppfyller kraven enligt följande direktiv: 89/392/EEG  
91/368/EEG

Harmoniserande standarder som använts:  
BS EN 292 - 1  
BS EN 292 - 2

Datum: 21.12.2004 Underskrift:

Namn: R.J. Hiley  
Befattning: Product Manager

Tillverkad av: Levererad av:  
Ambic Equipment Ltd. (vid behov)  
1Parkside, Avenue Two  
Station Lane, Witney, Oxford OX28 4YF  
ENGLAND

**FIN**

#### EU VAATIMUSTENMUKAISUUSVAKUUTUS

Tuotteen nimi: Automated Teat Sprayer  
Typpi: ATS/400  
Muut tuntoimerkit: Serial Number

Tuote täyttää seuraavat direktiivit: 89/392/EEC  
91/368/EEC

Standardit joita käytetty:  
BS EN 292 - 1  
BS EN 292 - 2

Päivämäärä: 21.12.2004 Allekirjoitus:

Nimi: R.J. Hiley  
Asema: Product Manager

Valmistajan nimi ja osoite:  
Ambic Equipment Ltd. (kun osoitettavissa)  
1Parkside, Avenue Two  
Station Lane, Witney, Oxford OX28 4YF  
ENGLAND

**NL**

**B**

#### GELIJKVORMIGHEIDSATTEST EEG

Naam van het product: Automated Teat Sprayer  
Type: ATS/400  
Andere typische productgegevens: Serial Number

Het product voldoet aan de eisen van volgende richtlijnen: 89/392/EEC  
91/368/EEC

Algemeen gehanteerde normen:  
BS EN 292 - 1  
BS EN 292 - 2

Datum: 21.12.2004 Handtekening:

Naam: R.J. Hiley  
Functie: Product Manager

Naam & adres van de fabrikant:  
Ambic Equipment Ltd. (indien voorkomend)  
1Parkside, Avenue Two  
Station Lane, Witney, Oxford OX28 4YF  
ENGLAND

**E**

#### CE DECLARACIÓN DE CONFORMIDAD

Nombre del producto: Automated Teat Sprayer  
Tipo: ATS/400  
Otros datos identificativos: Serial Number

El producto cumple con los requerimientos de las siguientes normas: 89/392/CE  
91/368/CE

Normas que han sido utilizadas:  
BS EN 292 - 1  
BS EN 292 - 2

Fecha: 21.12.2004 Firmado:

Nombre: R.J. Hiley  
Cargo: Product Manager

Nombre y dirección del fabricante:  
Ambic Equipment Ltd. (cuando proceda)  
1Parkside, Avenue Two  
Station Lane, Witney, Oxford OX28 4YF  
ENGLAND

**I**

#### DICHIARAZIONE DI CONFORMITÀ CE

Nome del prodotto: Automated Teat Sprayer  
Tipo: ATS/400  
Altri dati per l'identificazione: Serial Number

Il prodotto è conforme alle seguenti direttive: 89/392/CE  
91/368/CE

Norme tecniche armonizzate utilizzate:  
BS EN 292 - 1  
BS EN 292 - 2

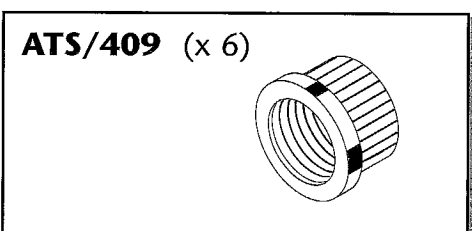
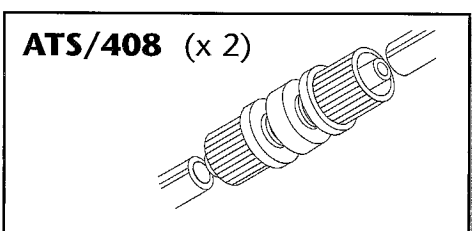
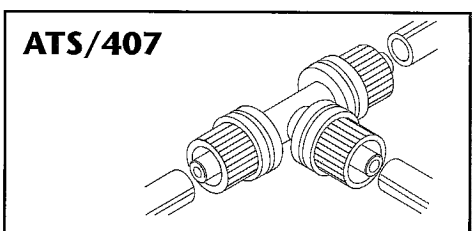
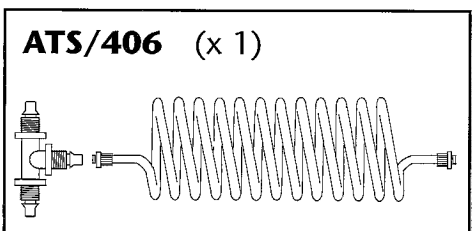
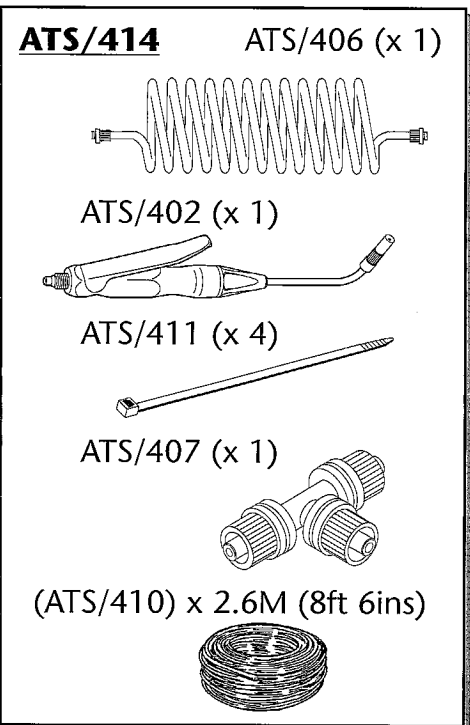
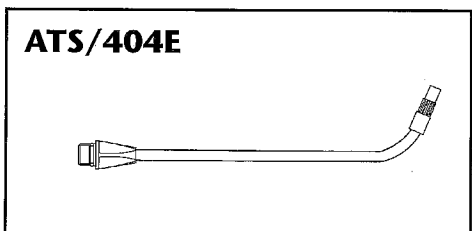
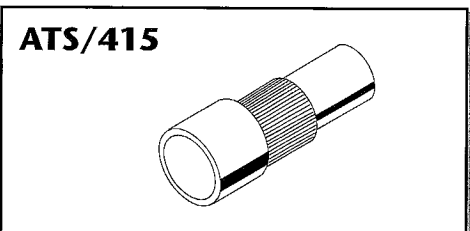
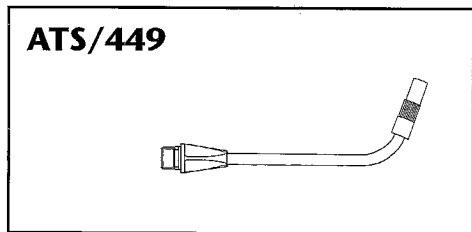
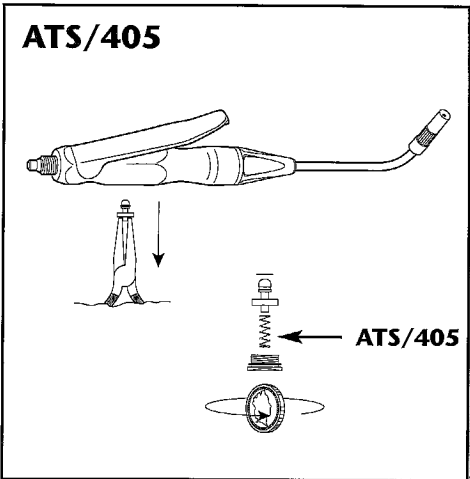
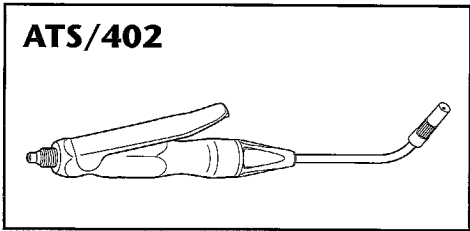
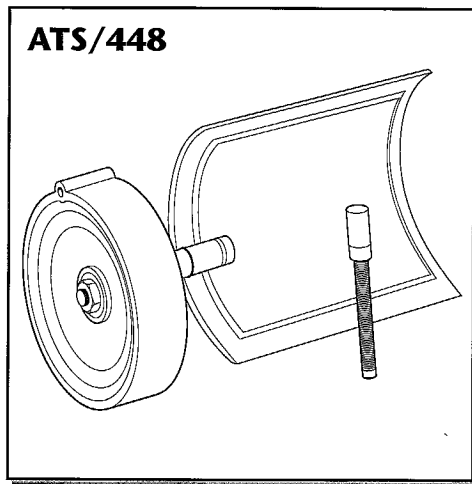
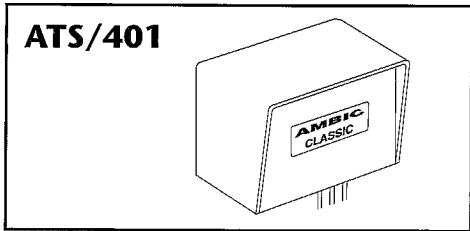
Data: 21.12.2004 Firma:

Nome: R.J. Hiley  
Posizione: Product Manager

Nome ed indirizzo del costruttore:  
Ambic Equipment Ltd. (quando applicabile)  
1Parkside, Avenue Two  
Station Lane, Witney, Oxford OX28 4YF  
ENGLAND

**14. SPARE PARTS**

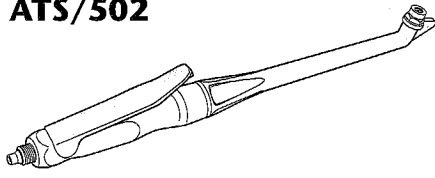
NOTE: NOT ALL SPARE PARTS ARE ILLUSTRATED. PLEASE CONTACT YOUR DEALER



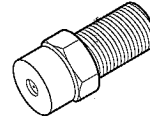
continued on next page



**ATS/502**



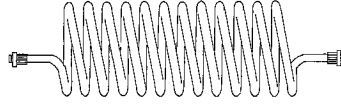
**AJS/2415**



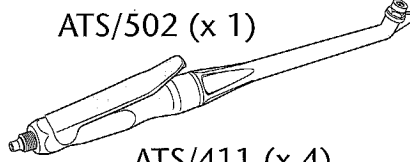
**ATS/504**



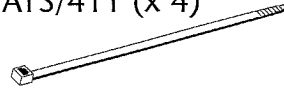
**ATS/514**      ATS/406 (x 1)



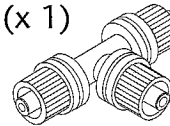
ATS/502 (x 1)



ATS/411 (x 4)



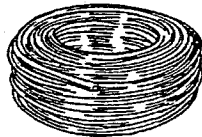
ATS/407 (x 1)



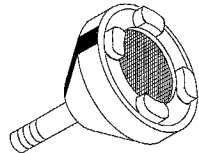
(ATS/410) x 2.6M (8ft 6ins)



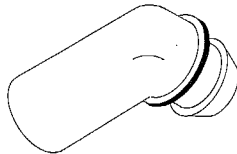
**ATS/410** x 6M (20ft)



**ATS/412**



**ATS/413**



**AJS/2005** – Ambic Spanner – **NEW**

Handy multi-function plastic spanner specifically designed for the installation and maintenance of the components of Ambic Teat Spraying systems.

